

# SATURN

SAT\_PEN\_23V1

# ILANEL



The Saturn pendant is inspired by the planet of the same name, effortlessly suspended mid-air. This cosmic luminaire features a faceted acrylic core, through which a ring of light is projected onto its surrounding. The two hemispheres are hand-turned from FSC solid timber, carefully selected for its wood grain characteristic and finished with low VOC water-based stains.

# SATURN

SAT\_PEN\_23V1

# ILANEL

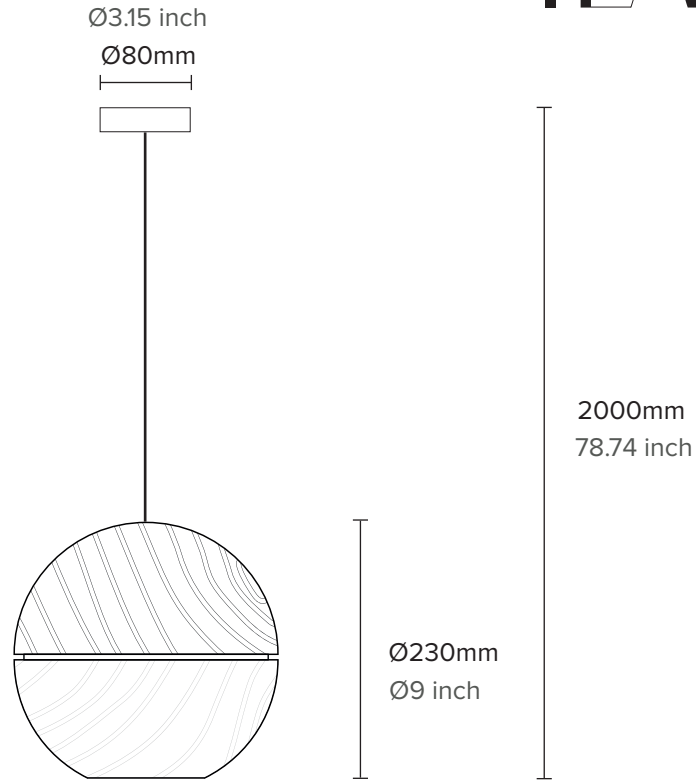

## TYPE

Pendant

## MATERIAL

Solid Timber, Acrylic

## WEIGHT

2.0kg

## MODEL

SAT-PEN

## LIGHT SOURCE

E27, Max 10W

*Light bulb not supplied unless requested*

## CERTIFICATION

ETL/UL upon request for North America

## CORD

2m Cotton Braided

*Custom lengths upon request*

## WARRANTY

3 years residential

2 years commercial

## DIMENSIONS

Ø230mm

## TIMBER FINISHES



**NATURAL**  
Sealed

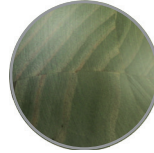

**OLIVE**  
Stained

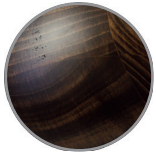

**WALNUT**  
Stained

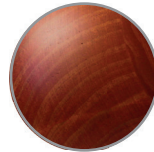

**TERRA**  
Stained



**LIME WHITE**  
Stained

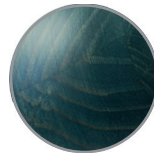

**AQUA**  
Stained



**ONYX**  
Stained



**CUSTOM**